



CONTACT

Quality Leader in
Truck Attachments

- Drum handlers
- Self powered attachments
- Lifting devices and booms
- Wide load handling
- Recycling containers
- Premises cleaning
- Fall prevention cages
- Truck forks



Contact Attachments
Mochdre Industrial Estate
Newtown
Powys
SY16 4LE

tel : 01686 611200
fax : 01686 611201

Four Fork Attachment

The safe solution for handling wide loads



Use :-

Designed for use when handling extra wide pallets or long products such as steel or plastic pipes, steel flats, plastic extrusions or timber. The truck forks slide into the inner sleeves and the outer forks support and balance the load for safety and the reduction of product damage.

Model Ref.	Capacity	Max Fork Width	Max Fork Thickness	Lost Load Center
FFA-1.0	1000 kg	140 mm	50 mm	80 mm
FFA-2.0	2000 kg	140 mm	50 mm	80 mm
FFA-3.0	3000 kg	140 mm	50 mm	80 mm
FFA-4.0	4000 kg	150 mm	60 mm	160 mm
FFA-5.0	5000 kg	150 mm	60 mm	160 mm

Ordering Information :-

Product Size & Weight?
Type of Product?
Dimensions S,W and L ?
Ground Clearance of Product (T)?
Fork Width & Thickness?
Truck Capacity?

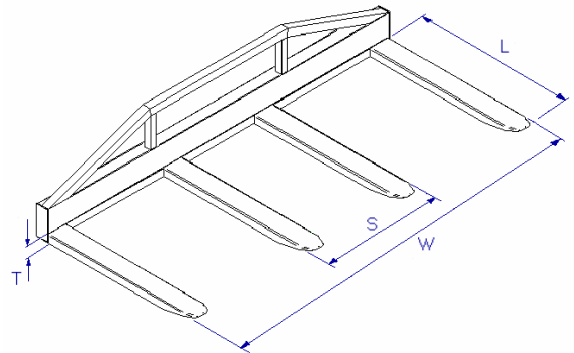

This attachment is manufactured to suit individual trucks and applications. It is important that the information below is provided when ordering.

Model Ref.	W (overall width)	L (Attachment fork length)	S (optimum truck spread)	T (Max fork thickness)
FFA-1.0				
FFA-2.0				
FFA-3.0				
FFA-4.0				
FFA-5.0				

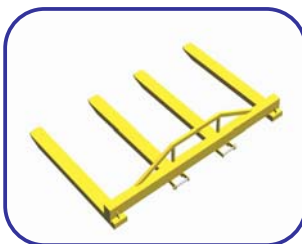

* Attachment Fork Length (L) must not exceed the truck forks by more than 50%

www.forklift-attachments.co.uk
email : sales@forklift-attachments.co.uk

Freephone
0800
028 3332

Call now for your personal
quote and further info

