



CONTACT

Quality Leader in
Truck Attachments

- Drum handlers
- Self powered attachments
- Lifting devices and booms
- Wide load handling
- Recycling containers
- Premises cleaning
- Fall prevention cages
- Truck forks



Contact Attachments
Mochdre Industrial Estate
Newtown
Powys
SY16 4LE

tel : 01686 611200
fax : 01686 611201

Six Fork Attachment

The safe solution for handling extra wide flexible loads



Use :-

Designed to increase load stability when handling extra wide pallets or products, or to carry three pallets alongside each other. The truck forks slide into the inner sleeves and 4 outer forks support and balance the load for safety and the reduction of production damage.

Model Ref.	Capacity	Max Fork Width	Max Fork Thickness	Lost Load Centre
SFA-1.0	1000 kg	140 mm	50 mm	80 mm
SFA-2.0	2000 kg	140 mm	50 mm	80 mm
SFA-3.0	3000 kg	140 mm	50 mm	80 mm

Ordering Information :-

- Product Size & Weight ?
- Type of Product ?
- Dimensions S,M,L and W ?
- Ground Clearance of Product (T) ?
- Fork Width & thickness?
- Truck Capacity?

This attachment is manufactured to suit individual trucks and applications. It is important that the information below is provided when ordering.

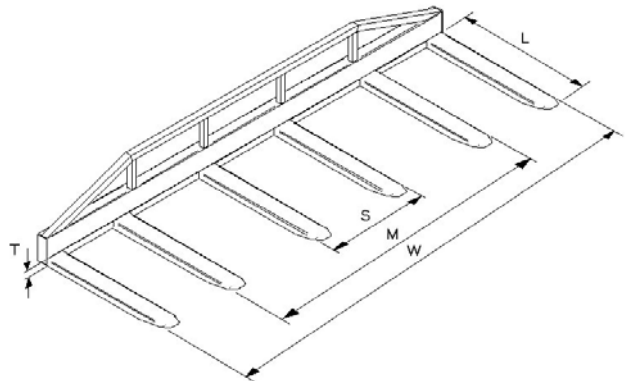

Model Ref.	W (maximum width)	L (Attachment fork length)	S (optimum truck spread)	M (middle fork spread)	T (Max fork thickness)
SFA-1.0					
SFA-2.0					
SFA-3.0					

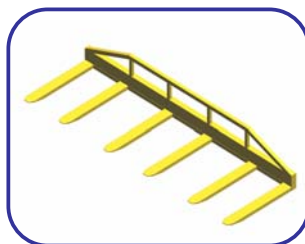

* Attachment Fork Length (L) must not exceed the truck forks by more than 50%

www.forklift-attachments.co.uk
email : sales@forklift-attachments.co.uk

Freephone
0800
028 3332

Call now for your personal
quote and further info

